

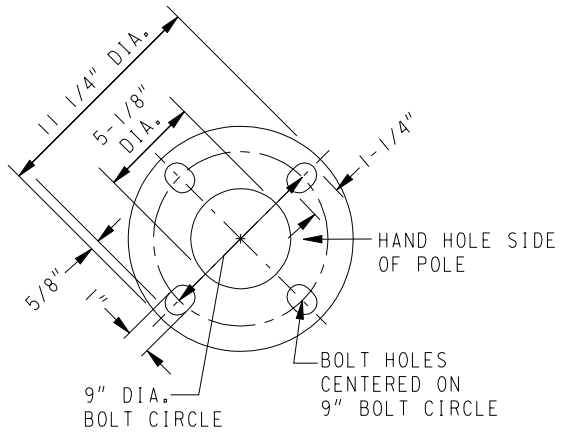

- NOTES:**
- 1.) ORNAMENTAL BASE SHALL BE SPLIT ASSEMBLY, CAST ALUMINUM BASE SHALL BE SMOOTH, STEPPED AS SHOWN.
 - 2.) A SECTION OF FLUTES SHALL TRANSITION BETWEEN SMOOTH BASE AND FLUTED, STEEL POLE.
 - 3.) HANDHOLE SHALL BE LOCATED ON FLAT SURFACE PARALLEL TO ROADWAY.
 - 4.) FLAG POLE HOLDER IS TO BE WELDED TO THE POLE BEFORE GALVANIZING.

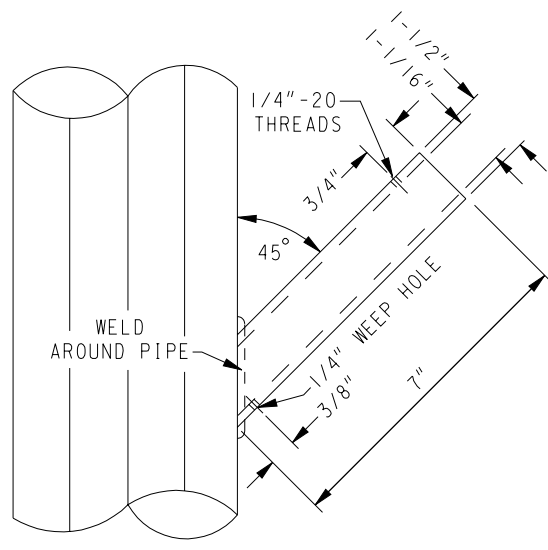

 <p>BUREAU OF TRAFFIC ENGINEERING AND ELECTRICAL SERVICES D.P.W. CITY OF MILWAUKEE</p>			
STREET LIGHTING			
TRAFFIC	J.O.#	W.O.	
DATE SIGNED	21' OCTAFLUTED STEEL POLE FOR WISCONSIN AVE. BRIDGE SPECIFICATION		
COMMUNICATIONS			
DATE SIGNED			
REVISION			
○	DRAWN BY JJP	DESIGNED BY EKL	CHECKED BY <i>[Signature]</i>
○	DATE SIGNED 10-19-07	DATE SIGNED 11-14-07	DATE SIGNED 10-08-08
○	SCALE: NA	DRG.#B-07-24	
○	REVISED BY:	REVISED DATE:	SHEET 1 of 1